

# **OPERATION, PARTS AND SAFETY MANUAL**

**SIGNODE®**

**4A1-114/114KR & 4A1-2  
MANUAL TENSIONERS**

**IMPORTANT!  
DO NOT DESTROY**

**It is the customer's responsibility to  
have all operators and servicemen  
read and understand this manual.**

Contact your local Signode representative  
for additional copies of this manual.

***READ ALL INSTRUCTIONS BEFORE OPERATING THIS SIGNODE PRODUCT***

# **WARNING**

READ THESE INSTRUCTIONS CAREFULLY. FAILURE TO FOLLOW THESE INSTRUCTIONS CAN RESULT IN SEVERE PERSONAL INJURY.

## GENERAL SAFETY CONSIDERATIONS

### 1. TOOL MANUAL

Before using this tool read and understand the operation manual.

### 2. STRAP BREAKAGE HAZARD

Never position yourself in-line with the strap during tensioning and sealing. Properly position yourself when tensioning and sealing as shown in the operating instructions.

Improper operation of the tool, sharp corners on the load, improper strap placement around the load or an unstable or shifted load could result in strap release or breakage, during tensioning. This could result in the following:

- ! A sudden loss of balance causing you to fall.
- ! Both tool and strap flying violently towards your face.

### 3. TRAINING

This tool must not be used by persons not properly trained in its use. Be certain that you receive proper training from your employer. If you have any questions contact your Signode Representative.

### 4. EYE INJURY HAZARD

Failure to wear safety glasses with side shields can result in severe eye injury or blindness. Always wear safety glasses with side shields which conform to ANSI Standard Z87.1 or EN 166.



### 5. FALL HAZARD

Maintaining improper footing and/or balance when operating the tool can cause you to fall. Do not use the tool when you are in an awkward position.

### 6. CUT HAZARD

Handling strap or sharp parts could result in cut hands or fingers. Wear protective gloves.



### 7. TOOL CARE

Take good care of the tool. Inspect and clean it daily, lubricate it weekly and adjust when necessary. Replace any worn or broken parts.

### 8. WORK AREA

Keep work areas uncluttered and well lighted.

# **WARNING**

## 9. WARNING LABEL 177896

The warning label shown below is on the tool handle. If this label becomes damaged, replace it immediately. Ensure that a plastic shrink tube sleeve is applied over the label. Contact your Signode Sales Representative if you have any questions.

** WARNING FAILURE TO FOLLOW THE INFORMATION BELOW COULD RESULT IN SERIOUS INJURY**

- Sudden strap breakage due to over tensioning will cause the tool to violently release from the strap. Always tension the strap by facing the edge of the load with your body well away from the edge so that if the strap breaks you don't fall off the load. If you are tensioning the strap using improper body position (with respect to the tool) on the top or side of load, you could fall if the strap breaks. Read the tool manual.
- Never extend the handle's length as this will make it easier to break the strap while tensioning.
- Wear safety glasses that conform to ANSI Standard Z87.1 or European Norm 166.

  
177896

## 10. CUTTING TENSIONED STRAP

- A. Keep all bystanders at a safe distance, away from the danger zone (shaded area) and possible flying strap ends.
- B. Stand to one side of the strap being cut - outside of the danger zone (shaded area).
- C. Cut the strap.

<b>TABLE OF CONTENTS</b>	<b>Page</b>
General Safety Instructions	2
Specifications	4
Operating Instructions Overview	5
Placement Around Load	6
Inserting Strap Into Tool	7
Top of Load	8
Side of Load	9
Wall Anchored Load	10
Part Removal & Replacement	12
Troubleshooting	16
Parts List	20

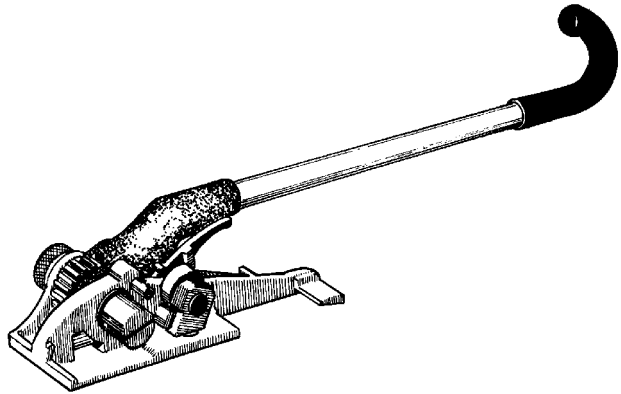

4A1-114, Part No. 184125  
4A1-114KR, Part No. 1844135  
4A1-2, Part No. 184140

## SPECIFICATIONS

TOOL MODEL	STRAP			SEALS
	TYPE	WIDTH	THICKNESS	
4A1-114 4A1-114KR	Magnus	1-1/4" Min.	.031" Min. to .050"	
4A1-2		2" Min.	.044" Min. to .050"	

## **WARNING**

With the 4A1-114 and 4A1-114KR tools, use only 1-1/4" wide (minimum) x .031" thick (minimum) hi tensile strap. With the 4A1-2 tool, use only 2" wide (minimum) x .044" thick (minimum) hi tensile strap. Failure to use the proper tool or strap can result in serious injury. Contact your Signode Sales Representative for the correct strap for your application.

## OPERATING INSTRUCTIONS

### **⚠ WARNING**

When tensioning or sealing, position yourself according to the operation instructions for the type of load being strapped. Keep all bystanders away.

It is recommended that safety belts be worn by operators working on at elevated positions.

Never increase the length of the tensioning handle by any means such as extending the handle length.

Apply tensions that are proper for the size and type of strap being used and is compatible with the loads being strapped and its corner characteristics. Contact your Signode Sales Representative if you have any questions.

Tuck the strap end back into the dispenser when you are not using it.

Operating instructions are broken down into the following sequences:

1. Placing strapping around a load.
2. Inserting strapping into tool.
3. Tensioning strap when on top of a load.
4. Tensioning vertical strap for sides of a load.
5. Tensioning strap for wall anchored load and horizontal strap.

The warning label shown below (177896) is installed on every tool handle. If this label becomes damaged, replace it immediately. Ensure that a plastic shrink tube sleeve is applied over the label. Contact your Signode Sales Representative if you have any questions.

**⚠ WARNING FAILURE TO FOLLOW THE INFORMATION BELOW COULD RESULT IN SERIOUS INJURY**

- Sudden strap breakage due to over tensioning will cause the tool to violently release from the strap. Always tension the strap by facing the edge of the load with your body well away from the edge so that if the strap breaks you don't fall off the load. If you are tensioning the strap using improper body position (with respect to the tool) on the top or side of load, you could fall if the strap breaks. Read the tool manual.
- Never extend the handle's length as this will make it easier to break the strap while tensioning.
- Wear safety glasses that conform to ANSI Standard Z87.1 or European Norm 166.



177896

## STRAP PLACEMENT AROUND LOAD

1. Place strap around load as shown in the illustrations.

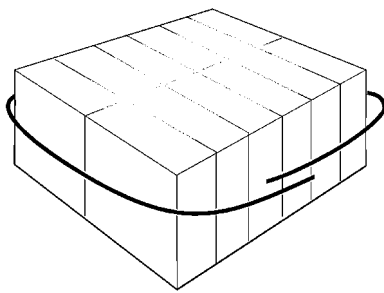

HORIZONTAL STRAP SIDE LOAD

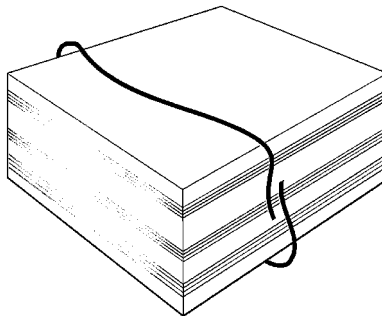

VERTICAL STRAP SIDE LOAD

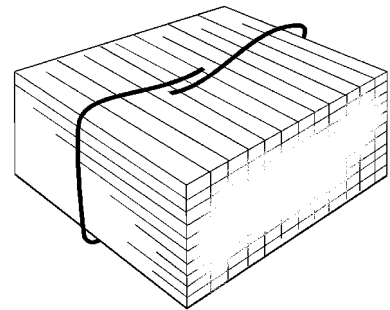

TOP STRAP LOAD

## WARNING

Failure to place the strap properly around the load or an unstable or shifted load could result in a sudden loss of strap tension during tensioning. This could result in a sudden loss of balance causing you to fall.

If the load corners are sharp use edge protectors.

Failure to follow the above could result in serious injury or death.

2. Thread the proper number of heavy duty seals on both straps, Contact your Signode Sales Representative for recommendations. Bend the lower/inner strap backwards to hold seals in place. Bend the upper/outer strap away from the load to permit insertion into the windlass of tensioner.

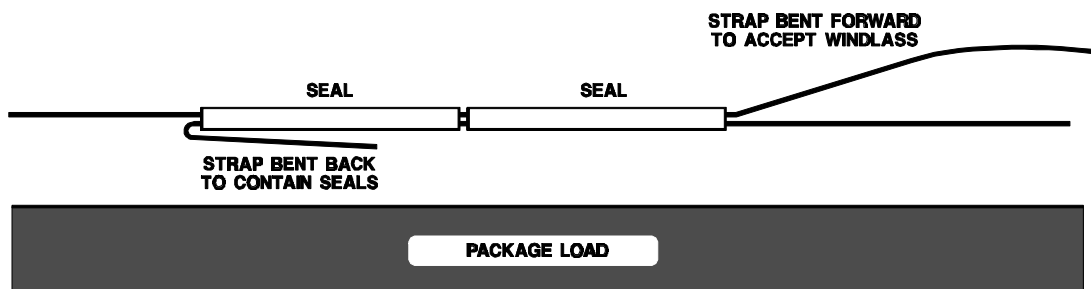

## INSERTING STRAP INTO THE TOOL

1. Rotate the tensioning handle all the way down to lock the gripper in the open position. Adjust the windlass so that the slot is in line with angle of strap.

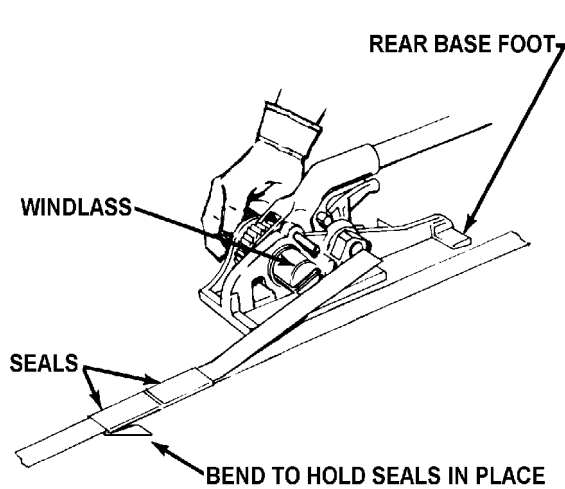

TYPICAL ORIENTATION FOR TOP LOADS

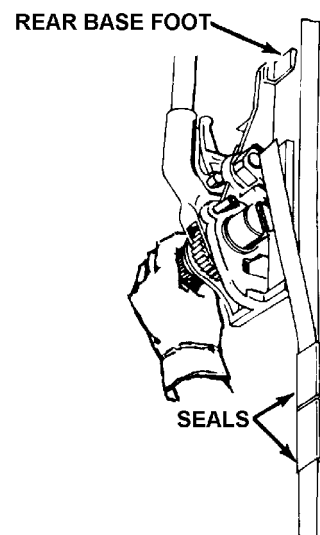

TYPICAL ORIENTATION FOR SIDE LOADS

2. Insert lower/inner strap in opening between gripper and base of tensioner until the strap is fully in contact with the inner wall of the base (strap guide). Make sure that the lower/inner strap is inserted over the base foot. Insert top/outer strap fully into windlass slot. Approximately 2 to 4 inches should extend beyond windlass; cut off any excessive length before tensioning.

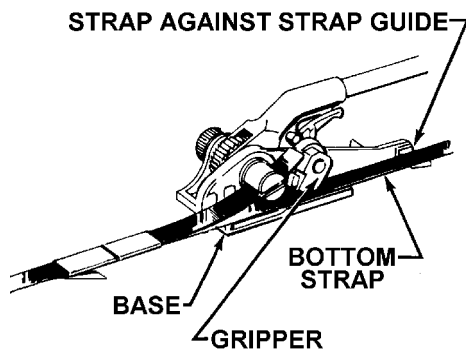

TYPICAL ORIENTATION FOR TOP LOADS

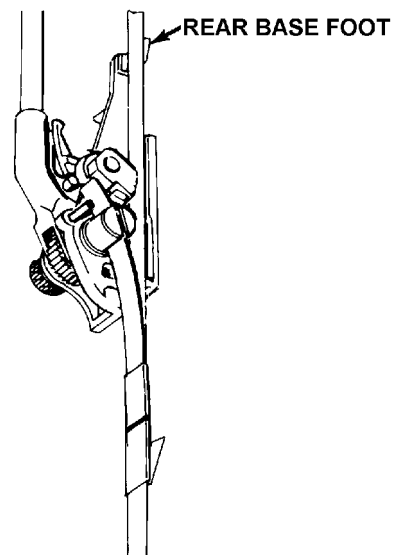

TYPICAL ORIENTATION FOR SIDE LOADS

## OPERATING INSTRUCTIONS FOR ON TOP OF LOAD

### **⚠ WARNING**

While tensioning strap, do not rotate the tensioning handle to the point where it will contact the gripper release cam. This will result in a sudden loss of strap tension. Be careful when applying final tension, as excessive tension could cause strap breakage. Position yourself in such a manner that strap breakage or hands slipping off the handle will not cause a loss of balance. Never increase the length of the tensioning handle by any means, such as, slipping a pipe over the handle to extend its length. If you have any questions contact your Signode Sales Representative.

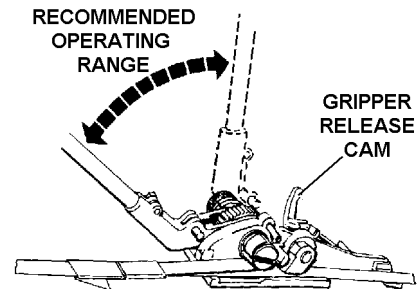

1. Bring tensioning handle upward, allowing the gripper to contact the lower strap. Rotate tensioning handle back and forth to take up slack in strap. When strap is snug, the operator should kneel perpendicular to the strap and apply the final tension using short tensioning strokes.

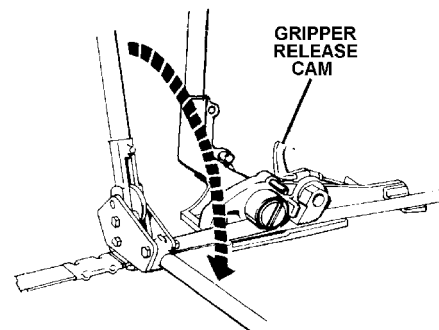

Consult your sealer manual for the proper number of crimps or notches needed for your application.

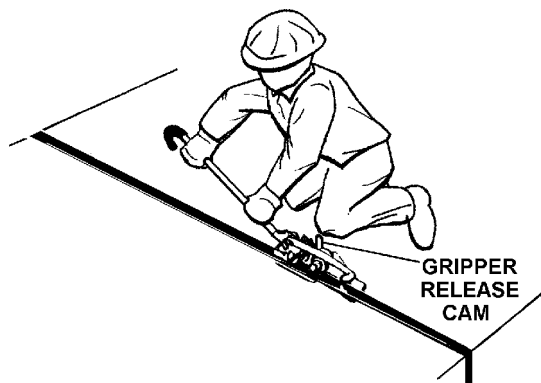

3. Release tensioner from strap by bringing handle down until gripper release cam locks in tensioning handle pin. Remove tensioner by twisting windlass slot out of strap curl and sliding tool away from strap.

2. Open sealer fully and center sealer jaws of sealer over each seal. Crimp or notch each seal the proper number of times by bringing the top handle downward as far as it will go.

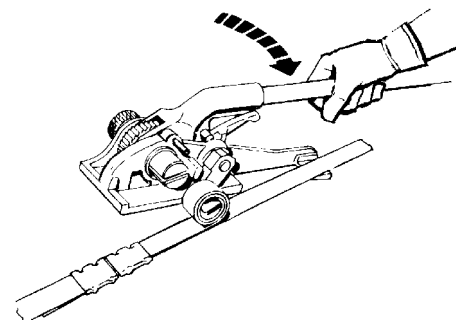



## OPERATING INSTRUCTIONS FOR SIDE OF LOAD (VERTICAL)

### **WARNING**

While tensioning strap, do not rotate the tensioning handle

the point where it will contact the gripper release cam. This will result in a sudden loss of strap tension. Be careful when applying final tension, as excessive tension could cause strap breakage. Position yourself in such a manner that strap breakage or hands slipping off the handle will not cause a loss of balance. Never increase the length of the tensioning handle by any means, such as, slipping a pipe over the handle to extend its length. If you have any questions

contact

your Signode Sales Representative.

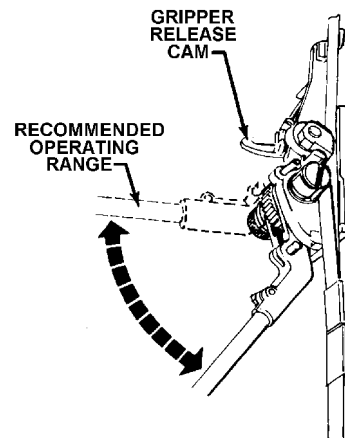

1. Bring tensioning handle downward, allowing the gripper to contact the lower strap. Rotate tensioning handle back and forth to take up slack in strap. When strap is snug, the operator should stand to the side of the tool and apply the final tension using short tensioning strokes.



Consult your sealer manual for the proper number of crimps or notches needed for your application.

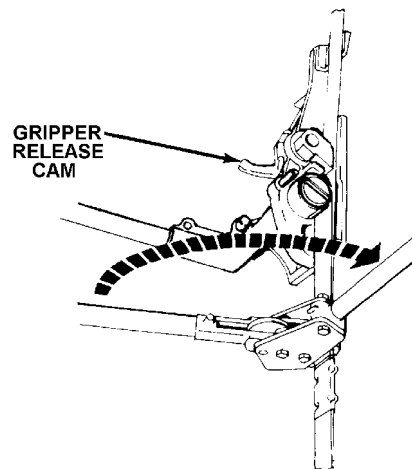

2. Open sealer fully and center sealer jaws of sealer over each seal. Crimp or notch each seal the proper number of times by bringing the top handle downward as far as it will go.
3. Release tensioner from strap by rotating handle until it contacts and locks into the gripper release cam. Remove tensioner by twisting windlass slot out of strap curl and sliding tool away from strap.

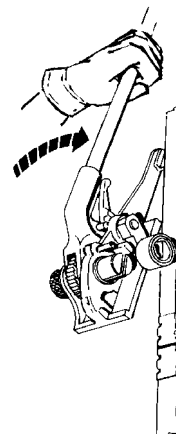

# OPERATING INSTRUCTIONS FOR WALL ANCHORED OR SIDE (HORIZONTAL) LOADS

The positioning of the tensioner on the strap for horizontal use is the same as on the top of load operation. After the slack strap is taken up, final tension is applied by short push type strokes, as illustrated below. Note that a tensioner is used on each strap to ensure equal tension. The sealing operation is also the same as for top of load use (Refer to top of load instructions).

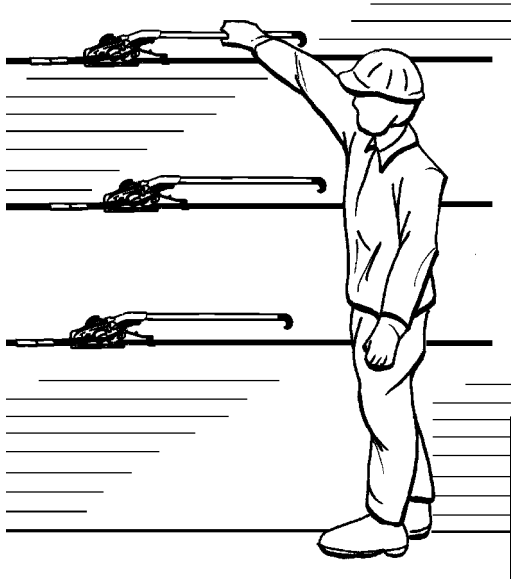
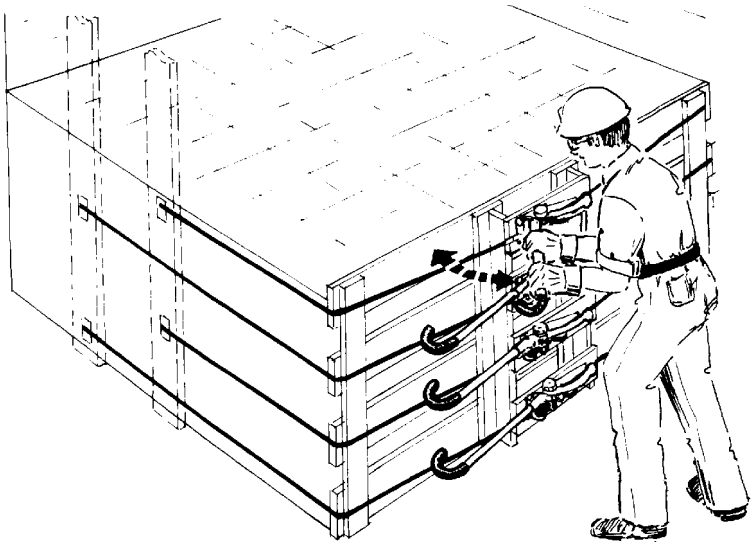

## PART REMOVAL AND REPLACEMENT

### GRIPPER, GRIPPER SPRING, GRIPPER PLATE

1. To remove the gripper and the gripper spring (20 and 22), drive the roll pin (21) out of the gripper using a 3/16" pin punch. Pull the gripper and gripper spring off the gripper shaft. Inspect and replace as required. Before reassembling, clean the exposed end of the gripper shaft and lubricate using light machine oil. Do not use grease. Reassemble in reverse order.
2. To replace the gripper plate (29) remove the two gripper plate screws (31) and lift the gripper plate out of the base. Be careful not to lose the shims (30) beneath the gripper plate. Before installing a new gripper plate, blow any dirt out of the hole in the base. The gripper plate must be installed flush to 1/64" above the base surface as shown in Figure 1. Apply one drop of Loctite sealant #242 to each screw. Reassemble in reverse order. After reassembling the tool, do not use for 12 hours to permit Loctite sealant to harden.

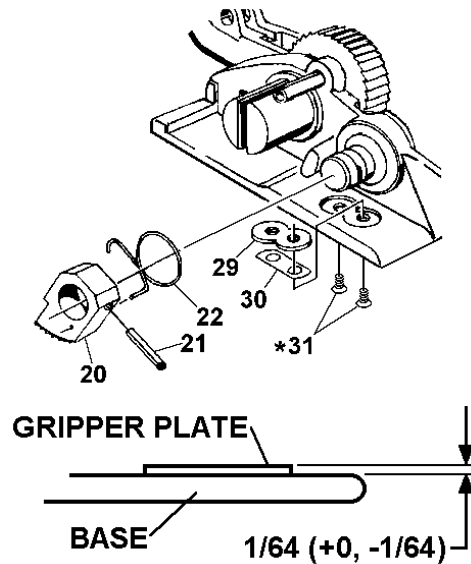

## **⚠ WARNING**

The top of the gripper plate must be only slightly above the top of the base. Failure to install the gripper plate properly can cause a loss of strap tension.

### TENSION HANDLE ASSEMBLY, WINDLASS SHAFT, AND RATCHET WHEEL.

1. Remove the retaining wire (19) from the windlass knob (17). Remove the cap screw (18) from the windlass shaft (14). Pull the windlass knob off the end of the windlass shaft.
2. Slide the windlass shaft out of the base (32) and lift out the tension handle assembly. The ratchet wheel can then be removed and inspected.
3. To remove the handle pawl (10) from the yoke handle weldment (2), first remove the Klipring Truarc (7) from the slot on the pawl pin (5). Press the pawl pin out of the handle yoke by pushing on the pin from the Truarc side of the pin. Once the pawl pin is removed, remove the handle pawl aligning set screw (3). The pawl cam, handle pawl, pawl spring and spring washer (6, 10, 9 and 8) can now be removed and inspected. Before reassembling, clean all parts thoroughly in solvent, particularly the hole in the handle yoke for the handle pawl. Lubricate all moving parts with light machine oil and reassemble in reverse order.

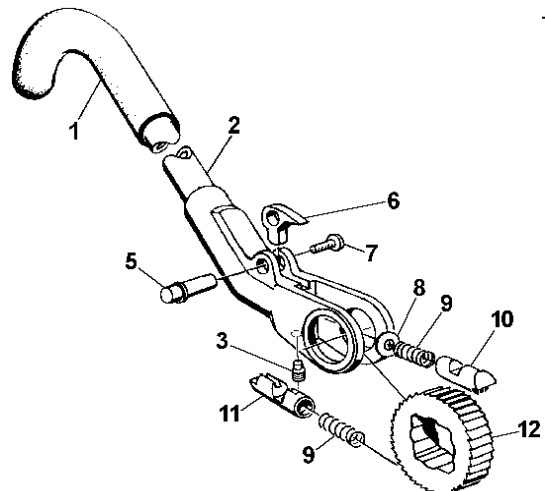

- Should it be necessary to replace the windlass shaft bushings (15 and 16), it is recommended that each bushing be driven out of the base by using pieces of rod or pipe with smaller diameters than the holes in the base. If pipe of the correct size cannot be obtained, the bushings can be driven out with a pin punch. Before installing new bushings, apply one drop of Loctite sealant #242 to each outer bushing surface. It is recommended that the bushings be pressed into the base. Be careful not to damage the edges of the bushings during installation.
- Before reassembling the tool, clean ratchet wheel, windlass shaft, and yoke handle assembly thoroughly. Lubricate all moving parts with light machine oil. Do not use grease. Reassemble in reverse order.

*NOTE: To tighten cap screw on windlass knob, first rotate slot in the windlass shaft to vertical position. Cut two (2) pieces of strap about 6" long and insert in windlass slot. Place one drop of Loctite sealant #242 on cap screw threads. Use strap to prevent windlass from turning as cap screw is tightened. DO NOT USE a screwdriver to prevent windlass from turning as windlass slot can be damaged. After cap screw is tightened, install a new retaining wire as shown.*

**THREAD WIRE (19) THROUGH HOLD IN SCREW (18) AND THROUGH HOLE IN PIN (14), TWIST WIRE ENDS UNTIL SNUG.**

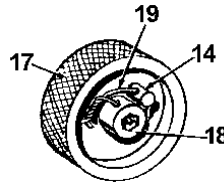

## **⚠ WARNING**

Never use Loctite or any similar adhesive on handle pawl aligning set screw (3) as this could cause the handle pawl to stick and not engage the ratchet gear properly.

### GRIPPER SHAFT, CAM PUSH ROD, AND BASE PAWL

- Remove the gripper and the gripper spring in accordance with the instructions on the previous pages.
- To remove the gripper shaft and the cam push rod, place the tension handle assembly in the forward position and manually return the gripper release cam (24) to the full rear position. Working from the top of the tool with a pin punch, drive the roll pin (26) out of the gripper release cam. It will be necessary to rotate the gripper release cam forward after the roll pin is part way through the gripper release cam to obtain clearance to drive the roll pin all the way out. After the roll pin is removed, rotate the gripper release cam to the full forward position. Tap the gripper shaft (23) out of the base. Once the gripper shaft is removed, the gripper release cam, cam push rod, spring, and pawl cam (24, 27, 28 and 6) can be removed and inspected.

## PART REMOVAL AND REPLACEMENT, Continued

3. Should it be necessary to replace or service the base pawl (11), the tension handle assembly, windlass shaft, and the ratchet wheel must be removed first. See instructions on previous pages. Once the ratchet wheel is removed, remove the base pawl aligning set screw (3). The base pawl and spring can now be removed and inspected.

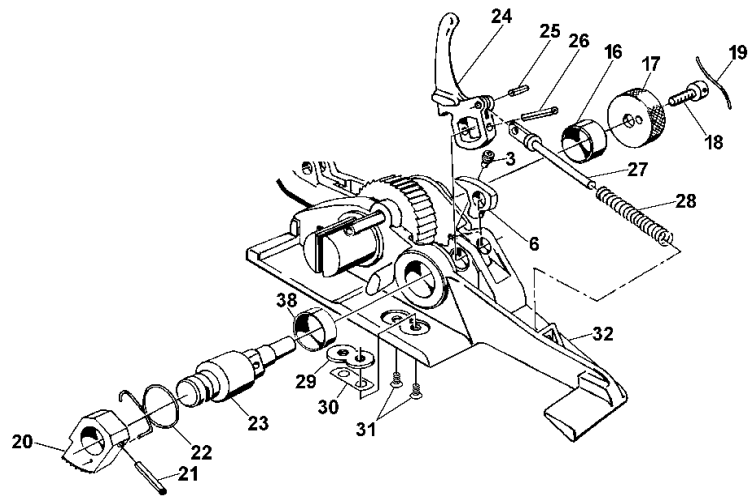

4. Before reassembling the tool, clean all parts thoroughly in solvent and allow to dry completely. All moving parts should be lubricated with light machine oil.
5. To reassemble the tool, install the pawl spring, set screw, and base pawl into the base. Next, assemble the ratchet wheel, tension handle assembly, and windlass shaft. See instructions on previous pages. To install the gripper shaft, use the following procedure:
  - a. Ensure that the gripper release cam (24) is pinned to the cam push rod (27) with the roll pin (25).
  - b. Slide cam push rod spring (28) onto the cam push rod.
  - c. Set gripper release cam assembly into the appropriate position in the base with end of the cam push rod extending through the hole in the base.
  - d. Set pawl cam (6) in position in the base.
  - e. Insert the gripper shaft into the base and through the gripper release cam. The gripper shaft will only go part way through the gripper release cam.
  - f. Pull the gripper release cam to the full rear position, see Figure 4.
  - g. Insert a screwdriver between the gripper release cam and the base. Use the screwdriver to pry the gripper release cam towards the rear of the tool. At the same time, rotate the gripper shaft until the square part of the gripper shaft slides into the square hole in the gripper release cam.

**NOTE:** When sliding the gripper shaft into the gripper release cam, ensure that the wide radius on the gripper shaft is facing down.

- h. Push the gripper shaft fully into the base.
- i. Remove the screwdriver and install the roll pin (26) into the hole in the gripper release cam.
- j. Install the gripper (20) and gripper spring (22).

***NOTE: After the tool is reassembled, crank the tension handle several times to be sure that set screws (3) are not binding the handle pawl or base pawl. If either pawl is binding, turn the appropriate set screw counterclockwise 1/2 turn at a time and recheck each time by cranking the handle.***

## TROUBLESHOOTING

The following items are the most common tool symptoms if problems occur. For symptoms or remedies not shown, contact your Signode service representative for additional information and details. The following tool symptoms are shown in this manual:

- #1 - Gripper will not hold lower strap.
- #2 - Strap slides off windlass shaft during tensioning.
- #3 - Tensioning handle slips during tension stroke.
- #4 - Tool will not hold tension.

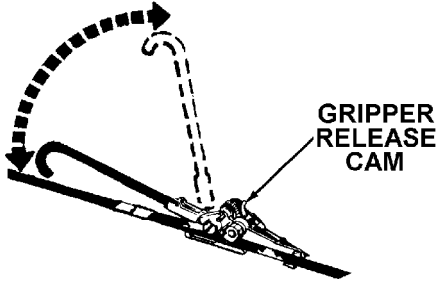
#1 SYMPTOM: Gripper will not hold lower strap.	
CAUSE	REMEDY
<p>1. Operator is bringing tension handle too far back allowing tension handle to hit gripper release cam.</p>	<p>1. While tensioning strap, do not rotate the tensioning handle to the point where it will contact the gripper release cam. This will result in a loss of strap tension.</p> 
<p>2. Gripper spring (22) is weak or broken.</p>	<p>2. Replace gripper spring. See Parts Removal and Replacement Instructions.</p>
<p>3. Dirt in gripper teeth.</p>	<p>3. Clean gripper teeth and apply light machine oil to end of gripper shaft. Do not use grease.</p>
<p>4. Gripper teeth worn.</p>	<p>4. Replace gripper and apply light machine oil to end of gripper shaft. Do not use grease.</p>
<p>5. Gripper plate (29) is worn. Top of plate must be above base.</p>	<p>5. Replace gripper plate. See Parts Removal and Removal Instructions.</p>
<p>6. Dirt or rust has accumulated between gripper and gripper shaft preventing gripper from rotating.</p>	<p>6. Remove gripper (see Parts Removal and Removal Instructions). Clean hole in gripper and exposed end of gripper shaft, then lubricate using light machine oil. Do not use grease.</p>
<p>7. A bent or dirty cam push rod (27) or weak spring (25) prevents gripper shaft from rotating.</p>	<p>7. Replace cam push rod and spring. Clean and apply light machine oil to all moving parts.</p>

<b>#2 SYMPTOM: Strap slides off windlass shaft during tensioning.</b>	
<b>CAUSE</b>	<b>REMEDY</b>
1. Strap not inserted fully inserted into windlass shaft slot during strap loading.	1. Push strap fully into slot during initial tensioning strokes. See Operating Instructions for details.
2. Tool is not kept in line with strap during tensioning.	2. Keep tensioning handle in line with strap during tensioning.
3. Excessive amount of strap being wound onto windlass shaft.	3. Cut off strap 2 to 4" beyond windlass. See Operating Instructions for details.

<b>#3 SYMPTOM: Tensioning handle slips during tension stroke.</b>	
<b>CAUSE</b>	<b>REMEDY</b>
1. Handle pawl is clogged by dirt or rust preventing free movement of handle pawl.	1. Remove tension handle, handle pawl, spring and ratchet wheel. Clean parts and hole in handle yoke and apply light machine oil to moving parts. See Parts Removal and Replacement.
2. Tip of handle pawl is heavily worn or chipped.	2. Replace handle pawl and lubricate with light machine oil. See Parts Removal and Replacement.
3. Teeth on ratchet wheel are heavily worn or chipped.	3. Replace ratchet wheel and lubricate with light machine oil. See Parts Removal and Replacement.
4. Windlass shaft bushings (15 and 16) are heavily worn allowing windlass shaft to wobble. This may cause improper ratchet wheel/handle pawl alignment.	4. Replace bushings and lubricate with light machine oil. See Parts Removal and Replacement.



## TROUBLESHOOTING, Continued

<b>#4 SYMPTOM: Tool will not hold tension.</b>	
<b>CAUSE</b>	<b>REMEDY</b>
1. Base pawl is clogged by dirt preventing free movement of base pawl.	1. Remove base pawl, spring and ratchet wheel. Clean parts and hole in handle yoke and apply light machine oil to moving parts. See Parts Removal and Replacement.
2. Tip of base pawl is heavily worn or chipped.	2. Replace base pawl and lubricate with light machine oil. See Parts Removal and Replacement.
3. Teeth on ratchet wheel are heavily worn or chipped.	3. Replace ratchet wheel and lubricate with light machine oil. See Parts Removal and Replacement.
4. Windlass shaft bushings (15 and 16) are heavily worn allowing windlass shaft to wobble. This may cause improper ratchet wheel/handle pawl alignment.	4. Replace bushings and lubricate with light machine oil. See Parts Removal and Replacement.

## SIGNODE NEW TOOL WARRANTY

Signode Engineered Products Warrants that a new Signode strapping tool will operate per functional specifications for a period of sixty (60) days after the date of shipment to the owner's place of business. Normal wearing parts, as outlined in the Operation, Parts & Safety manual, are covered by a thirty (30) day warranty unless, in Signode's judgement, these parts have been subjected to abnormal or extreme usage. Signode's sole liability hereunder will be to repair or replace, without charge, F.O.B. Signode's Glenview, Illinois plant, any tool which proves to not operate per functional specifications within the stated period. Signode reserves the right to replace any tool which proves not to operate per functional specifications with a new or like-new tool of the same model if in Signode's judgement such replacement is appropriate. Any new replacement tool provided to an owner will carry a full sixty (60) day warranty. Any warranty repaired tool or like-new replacement tool will carry a warranty for the balance of the time remaining on the initial sixty (60) day warranty. This warranty will be extended to compensate for the time the tool is in Signode's possession for warranty repairs.

This warranty is void as to any tool which has been: (I) subjected to mis-use, misapplication, accident, damage, or repaired with other than genuine Signode replacement parts, (II) improperly maintained, or adjusted, or damaged in transit or handling; (III) used with improperly filtered, unlubricated air or improper strapping material, (IV) in Signode's opinion, altered or repaired in a way that affects or detracts from the performance of the tool.

**SIGNODE MAKES NO WARRANTY, EXPRESSED OR IMPLIED, RELATING TO MERCHANTABILITY, FITNESS OR OTHERWISE EXCEPT AS STATED ABOVE AND SIGNODE'S LIABILITY AS ASSUMED ABOVE IS IN LIEU OF ALL OTHERS ARISING OUT OF OR IN CONNECTION WITH THE USE AND PERFORMANCE OF THE TOOL. IT IS EXPRESSLY UNDERSTOOD THAT SIGNODE SHALL IN NO EVENT BE LIABLE FOR ANY INDIRECT OR CONSEQUENTIAL DAMAGES INCLUDING, BUT NOT LIMITED TO, DAMAGES WHICH MAY ARISE FROM LOSS OF ANTICIPATED PROFITS OR PRODUCTION, SPOILAGE OF MATERIALS, INCREASED COSTS OF OPERATION OR OTHERWISE.**

Considerable effort has been made to ensure that this product conforms to our high quality standards. However, should you experience any difficulties, please contact your Sales Representative providing samples and the manufacturing code specified on the tool.

PART #	DESCRIPTION	AREA OF USE
<b>LUBRICANTS</b>		
177029	BROWN K-55 GREASE	CLUTCH DRIVES, INTERNAL GEARS, GEAR SETS
422792	WHITE LUBRIPLATE GR-132 GREASE	PNEUMATIC PARTS, AIR CYLINDERS, AIR VALVES, O-RINGS
422793	BLACK LUBRIPLATE 3000W GREASE	MOVING INTERNAL PARTS, JAWS, LINKS
432322	EP ACCROLUBE GREASE	HIGH FRICTION CONTACT PARTS
008556	LS-1236 AIR LINE OIL	AIR MOTORS, AIR VALVES
<b>ADHESIVES</b>		
422794	LOCTITE #222, PURPLE	LOW STRENGTH, SCREWS 1/4" (6MM) OR SMALLER SIZES
422795	LOCTITE #242, BLUE	MEDIUM STRENGTH, SCREWS 5/16" (8MM) OR LARGER SIZES
422796	LOCTITE #271, RED	HIGH STRENGTH, SEMI-PERMANENT SCREW APPLICATION
422797	LOCTITE #309, GREEN	PERMANENT, CURVED SURFACE PART CONTACT
274111	LOCTITE #380, BLACK MAX	PERMANENT, FLAT SURFACE PART CONTACT
<b>CLEANING BRUSHES</b>		
023963	SMALL BRUSH	FEEDWHEEL & GRIPPER TEETH
269589	LARGE BRUSH	FEEDWHEEL & GRIPPER TEETH